

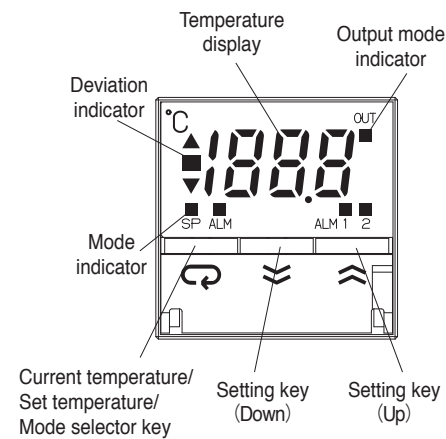

8. USING THE TEMPERATURE CONTROL METER



Set the temperature according to the following procedures.

(Factory setting is 250°C)

Press the selector key  located on the front. Confirm that the unit is in “Set Temperature” mode. (the mode indicator is illuminated).



Set the temperature using the UP and DOWN keys.

HAKKO 485
SOLDERING SYSTEM

Instruction Manual

Thank you for purchasing the HAKKO 485 soldering system.
Please read this manual before operating the HAKKO 485.
Keep this manual readily accessible for reference.

We supply Hakko 485 soldering system without solder for using lead-free users.
Although a little lead-free solder (Sn 97%, Ag 3%) still remains in the solder bath due to inspection before shipment. It will not effect the use or efficiency of this product.



HAKKO CORPORATION

HEAD OFFICE

4-5, Shiokusa 2-chome, Naniwa-ku, Osaka 556-0024 JAPAN
TEL:+81-6-6561-3225 FAX:+81-6-6561-8466
<http://www.hakko.com> E-mail:sales@hakko.com

OVERSEAS AFFILIATES

U.S.A.: AMERICAN HAKKO PRODUCTS, INC.

TEL: (661) 294-0090 FAX: (661) 294-0096

Toll Free (800)88-HAKKO

<http://www.hakkousa.com>

HONG KONG: HAKKO DEVELOPMENT CO., LTD.

TEL: 2811-5588 FAX: 2590-0217

<http://www.hakko.com.hk>

E-mail:info@hakko.com.hk

SINGAPORE: HAKKO PRODUCTS PTE., LTD.

TEL: 6748-2277 FAX: 6744-0033

<http://www.hakko.com.sg>

E-mail:sales@hakko.com.sg

Please access to the following address for the other Sales affiliates.

<http://www.hakko.com>

1. PACKING LIST

HAKKO 486 (Air unit)

HAKKO 485

Fig1



Anti-oxidizer (No.486-026)

Air hood for 42P (No.485-31)

Air hood for 28P (No.485-30)

Air hood for 18/20P (No.485-29)

Air hood for 14/16P (No.485-28)

Nozzle for 42P (485-N-04)

Nozzle for 28P (485-N-03)

Nozzle for 18/20P (485-N-02)

Nozzle for 14/16P (485-N-01)

Lamp (No.485-10)

Leveling gauge (No.485-22)

Spatula (No.485-09)

IC tweezer (No.485-07)

Waste collector (No.485-23)

Positioning board (No.485-20)

7. SETTING UP

Sample of adjustment

HAKKO 485 and 486 Air unit

A. Through-hole P.W.B on both side

	HAKKO 485			HAKKO 486 (Air unit)		
	Nozzle	Temperature Control	Flow Time	Air Pressure	Delay	Time
Slow Down Dial Scale=MAX	14/16P	250°C (482°F)	5 sec.	0.4kg/cm ²	2.2 sec.	0.1 sec.
	18/20P	250°C (482°F)	5 sec.	0.4kg/cm ²	2.2 sec.	0.1 sec.
	28P	250°C (482°F)	5 sec.	0.5kg/cm ²	2.2 sec.	0.1 sec.
	42P	250°C (482°F)	5 sec.	0.5kg/cm ²	2.2 sec.	0.1 sec.
Slow Down Dial Scale=0	14/16P	250°C (482°F)	5 sec.	0.4kg/cm ²	0.6 sec.	0.1 sec.
	18/20P	250°C (482°F)	5 sec.	0.4kg/cm ²	0.6 sec.	0.1 sec.
	28P	250°C (482°F)	5 sec.	0.5kg/cm ²	0.6 sec.	0.1 sec.
	42P	250°C (482°F)	5 sec.	0.5kg/cm ²	0.6 sec.	0.1 sec.

- Set the "Flow Level" as the solder just begins to flow from the nozzle.
- When using a special-order nozzle (for connectors, etc.), set the "Delay Timer" on the Air Unit. Set the "Timer" while the air is blowing and just when there is 2-3 mm of solder under the top of the nozzle.

B. Multi Layers P.W.B.

For P.W.B. with more than 4 layers, preheat the board but don't increase the soldering temperature.

8. SPECIFICATIONS

Power consumption	850W
Temperature range	Normal temperature - 300°C (570°F)
Temperature accuracy	± 2°C (36°F)
Molten solder capacity	10kg (22lbs.)
Dimensions (WxHxD)	500 × 245 × 550 mm (19.7 × 9.6 × 21.7 in.)
Weight (w/o solder, cord)	35 kg (77 lbs.)

● HAKKO 486 (AIR UNIT)

Part No.	486
Air pressure	2 - 7 kgf/cm ²
Dimensions (WxHxD)	150 × 100 × 300 mm (5.9 × 3.9 × 11.8 in.)
Weight (w/o solder, cord)	3.5 kg (7.7 lbs.)

※ Specifications and design are subject to change without notice.

7) Place the Impeller into the Chamber and secure the Chamber to the bottom plate.
Place the Chamber into the bath over the 2 bolts.

8) Insert the Anti-oxidizer plate over the Impeller and the nearest bath bolt.

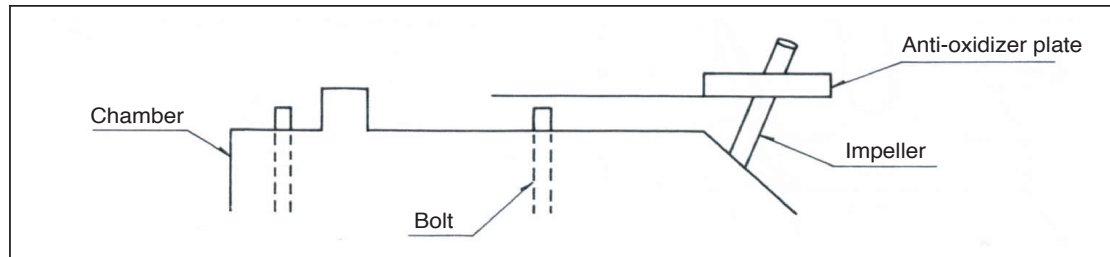

9) Align the D-shaped cuts on the impeller and the motor shaft through the hole in the joint and secure them with the 2 hex screw.

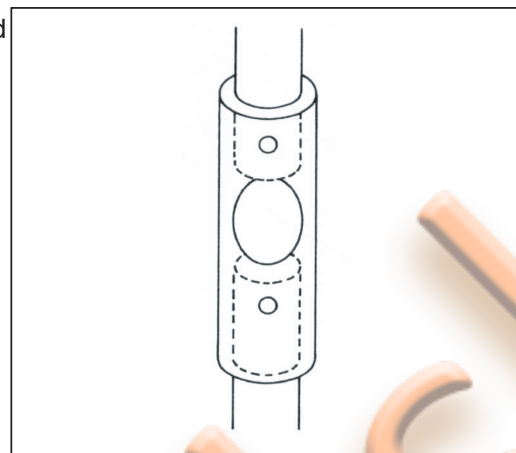

10) Turn on the motor. If the Impeller touched the bottom plate, adjust the Impeller so that it doesn't.

11) Place the Anti-oxidizer.

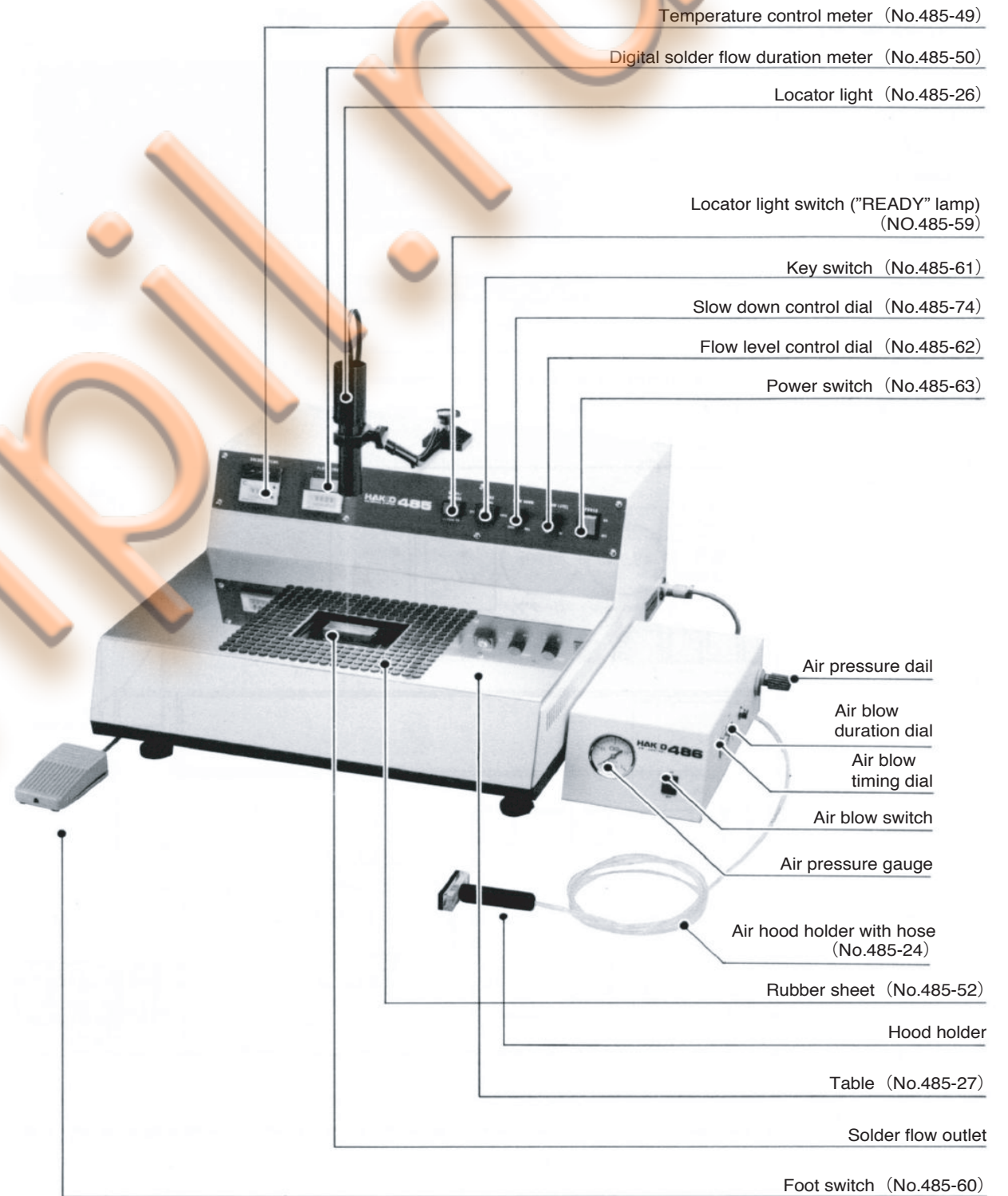
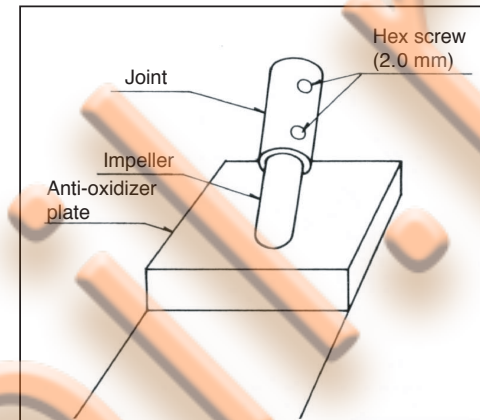
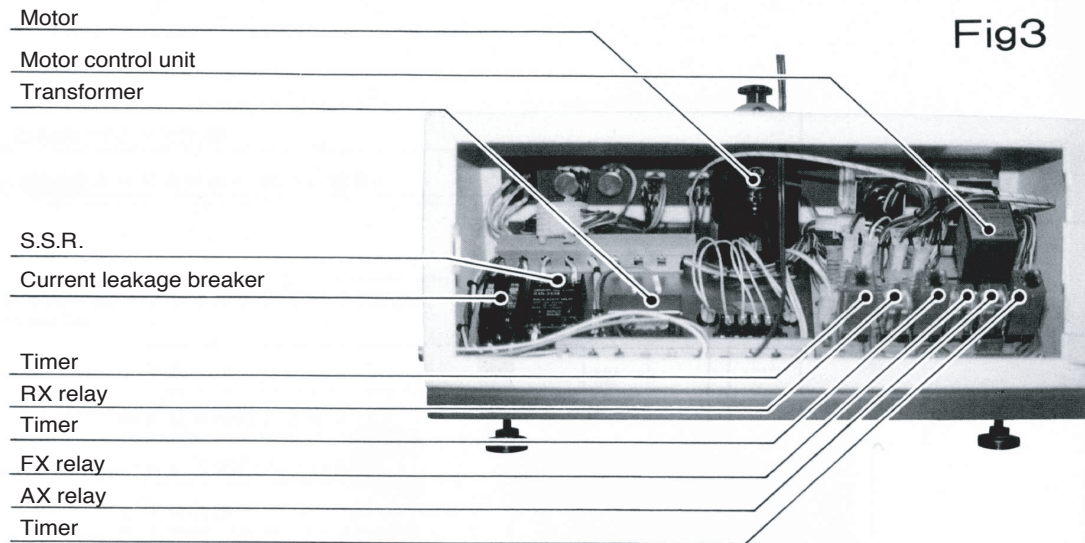

Fig2

2. THE INTERNAL PARTS OF THE BODY



2) Turn the power switch ON and wait 30 -40 minutes for the solder in the bath to melt.

3) Using a 2.0mm hex wrench, remove the 2 screws securing the joint to the impeller and let the impeller drop down.

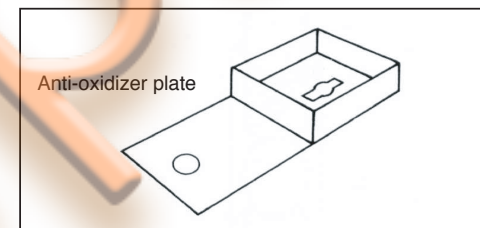

4) Remove the anti-oxidizer plate.

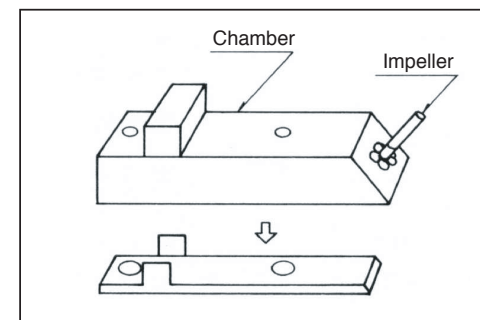
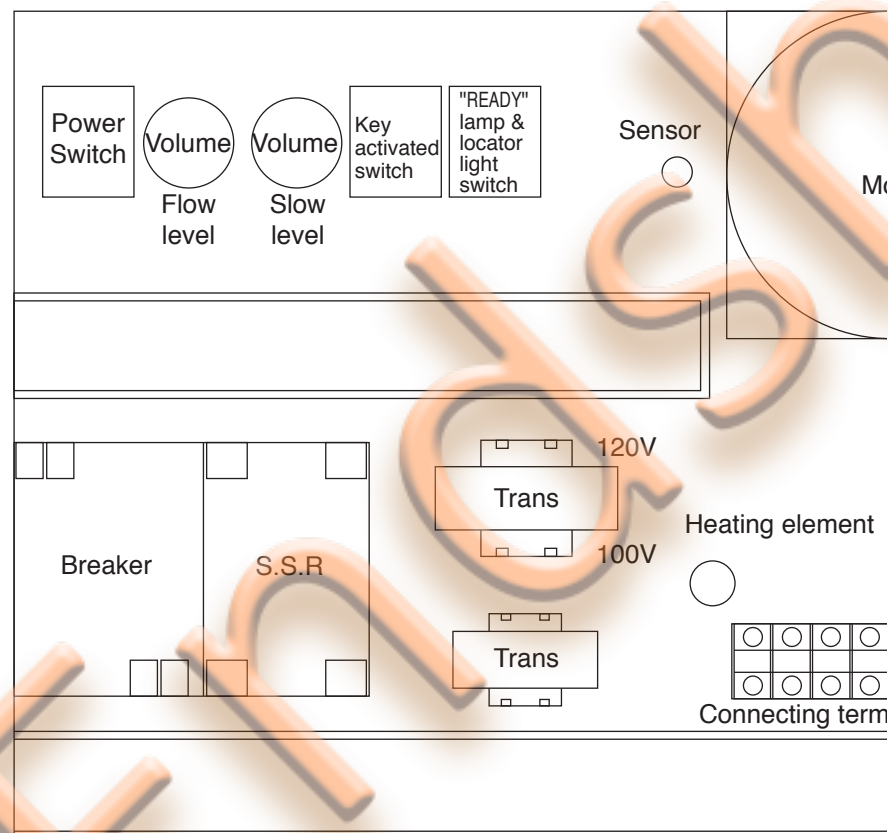

5) Grasp the impeller and the chamber with two pairs of pliers and gently pill the chamber away from the bottom plate.

Be sure not to spill or touch the melted solder in the bath while removing the chamber.

6) Remove any and all oxide from bottom plate using the provided spatula.

6. CLEANING THE SOLDER BATH

A. Daily cleaning

Clean before or after every use.

- Remove the table.
- Remove any and all oxide inside the bath using the provided spatula.
- Replace the anti-oxidizer on the anti-oxidizer plate.

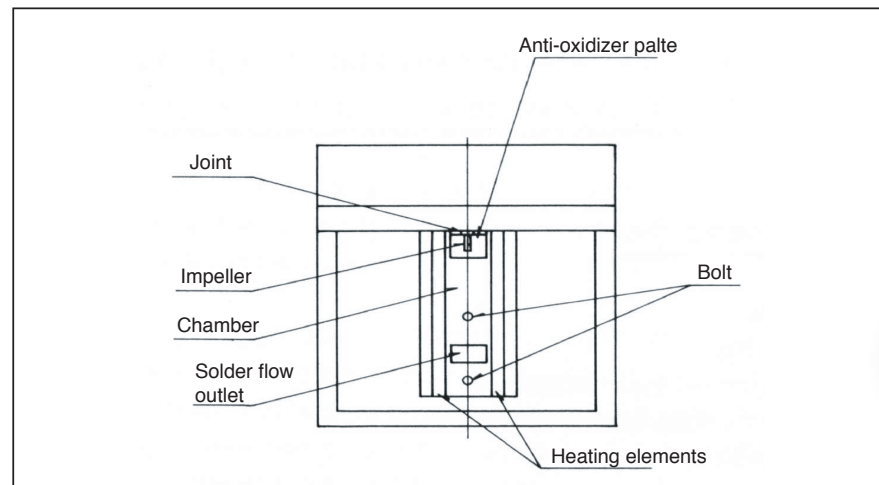

B. Monthly disassembly and cleaning

To keep the unit in good working condition, clean the unit once a month following the procedure described below.

- 1) With the power switch in the OFF position, remove the 2 nuts located at the top of the solder bath.

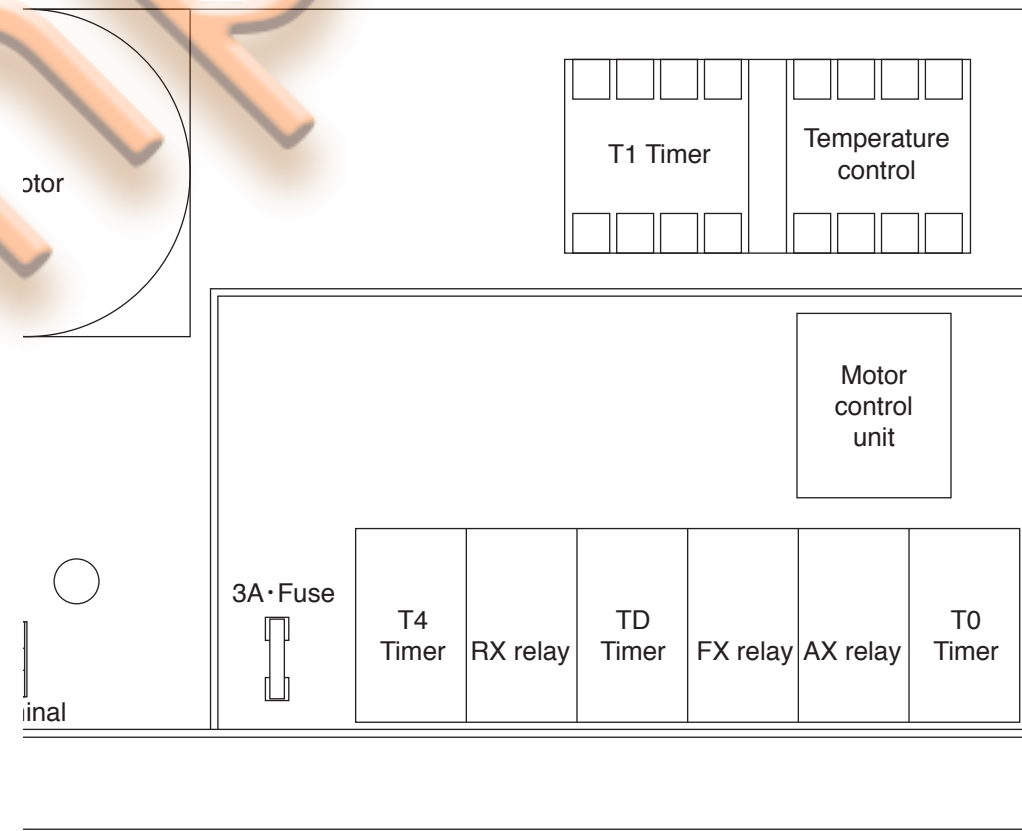
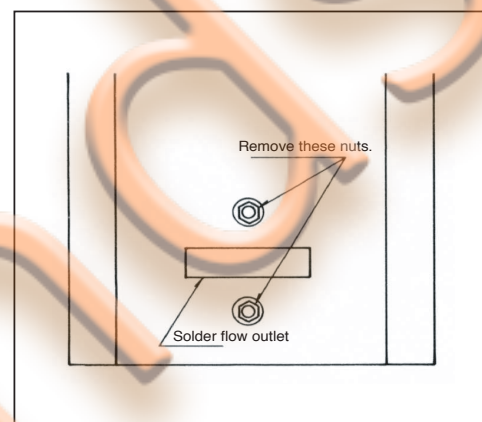

3. WIRING DIAGRAM / WARNINGS / SETTING UP

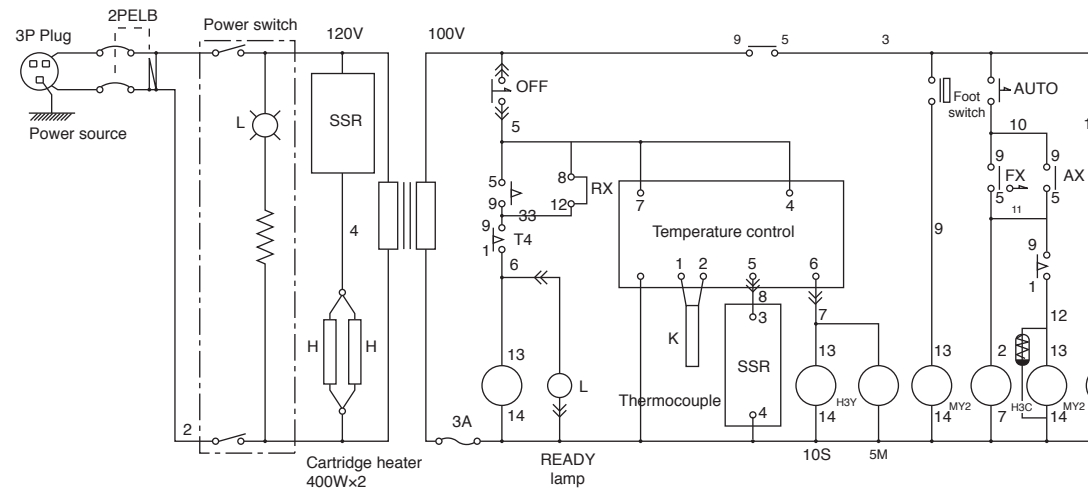

WARNING

The molten solder in the solder bath is dangerous since it reaches about 300°C/570°F. The solder bath and the unit also reach a high temperature when the power is ON. Wrong handling may cause burns or fire. Be sure to observe the following precautions.

- Use this product on highly stable metal workbench. Never use it near paper or other flammable materials.
- Inform others in the area that the product is hot and should not be touched.
- Never put water in the solder bath as this will cause solder to spatter out of the solder bath.
- Turn the power off when not in use, or left unattended.
- Before changing parts or storing the unit, be sure to turn the power off and allow the unit to cool to room temperature.
- Be careful not to spatter the solder when changing the nozzle.
- This appliance is not intended for use by persons (including children) with reduced physical, sensory or mental capabilities, or lack of experience and knowledge, unless they have been given supervision or instruction concerning use of the appliance by a person responsible for their safety.
- Children should be supervised to ensure that they do not play with the appliance.

Warnings and cautions are placed at critical points in this manual to direct the operator's attention to significant items. They are defined as follows:

- ⚠ **WARNING** : Failure to comply with a WARNING may result in serious injury or death.
- ⚠ **CAUTION** : Failure to comply with a CAUTION may result in injury to the operator, or damage to the items involved.

● Observe the following precautions to prevent accidents or damage to the units.

CAUTION

- Do not use the HAKKO 485 for applications other than soldering.
- Do not modify the HAKKO 485.
- Use only genuine HAKKO replacement parts.
- Do not allow the HAKKO 485 to become wet, or use it with wet hands.
- Be sure the work area is well ventilated. Soldering produces smoke.
- Do not do anything else that might be dangerous.

SETTING UP

1	2	3
Remove packing material and check enclosed accessories with Fig .1. (Some accessory parts will be found in the body.)	Put the locator light into the upper holder of the HAKKO 485, and secure it. Connect the plug to a power source.	Connect a compressor to the HAKKO 486 (Air unit).

Replacing the sensor

Loosen the temperature control terminals (1) and (2) in the rear portion of the unit. Pull the sensor out and replace it.

- (1) = red (+) terminal
- (2) = black (-) terminal

* Replace the sensor when the solder in the solder bath is melted.

Replacing the locator light

Unscrew the securing nut through the locator light cover hole. Pulling the light up, remove it and then replace it.

Trouble shooting the HAKKO 486 (Air unit)

If compressed air is not forced out after the solder has ceased flowing, the problem is one or more of the following :

1. The key activated switch has gone bad.
2. The air compressor is bad or one of the connections needs attention.
3. The dial has been improperly adjusted.
4. The T1 timer contact has gone bad.
5. The terminal connector joint cable is improperly connected.
6. The timer for the air control unit has gone bad.
7. The valve has gone bad.

5. TROUBLE SHOOTING GUIDE

- If the "POWER" lamp should fail to light, yet the solder bath has reached the desired temperature, check whether the bulb needs to be replaced.
- Should the solder bath not heat to the desired temperature, although the ▼ (red) lamp lights, the cause is likely one or more of the following:

1. Operational failure of SSR semiconductor switch
2. Thermocouple malfunction
3. Temperature controller malfunction
4. Heater is broken

If the thermocouple goes bad, the UP arrow(▲) on the temperature control meter will light after the unit is switched on.

- If the solder does not flow so much when foot switch is depressed although "READY" lamp lights, the oxides are deposited.
If the solder does not flow at all when foot switch is depressed although "READY" lamp lights, operational failure of motor control unit occurs.
- If the "READY" lamp fails to light, yet the solder flows, check to see if the bulb needs to be replaced.
- If locator light does not light up even it's switched on after "READY" lamp lights, replace the lamp.

If the solder does not flow when foot switch is depressed in MANUAL mode.

- Foot switch -
Open the rear panel of the unit, depress the foot switch, and determine whether the FX relay is working or not. If it is not working properly, then replace the foot switch. (Normally, when the foot switch is depressed, the relay will make a rattling sound.)
- Solder flow dial, Motor, Motor control Unit -
If the FX relay is working properly but the solder still does not flow, then the contact of the FX relay is likely bad or components related to the motor control unit are bad.
Remove the work table and depress the foot switch
 1. If the motor fails to work, then (1) the FX relay, or (2) the motor, the control, the motor control, the condenser, or the flow level dial has gone bad.
 2. If the motor does operate, then the impeller in the solder bath has gone bad.

If the solder does not flow when foot switch is depressed in AUTO mode.

- The causes are almost identical to those of the MANUAL mode, with the exception that the time setting circuit may have gone bad.
- If the solder continues to flow in spite of the timer setting, then T1 Timer or FX relay has gone bad.
- Timer setting value is abnormal.

Replacing the heater

- 1) Open the rear panel of the unit. Remove the four white wires from the connecting terminal.
- 2) Remove the work table and pull out heat insulating material from the front of the solder bath. Unscrew the two securing nuts with a hex key wrench.
- 3) Push the heater forward and replace them.

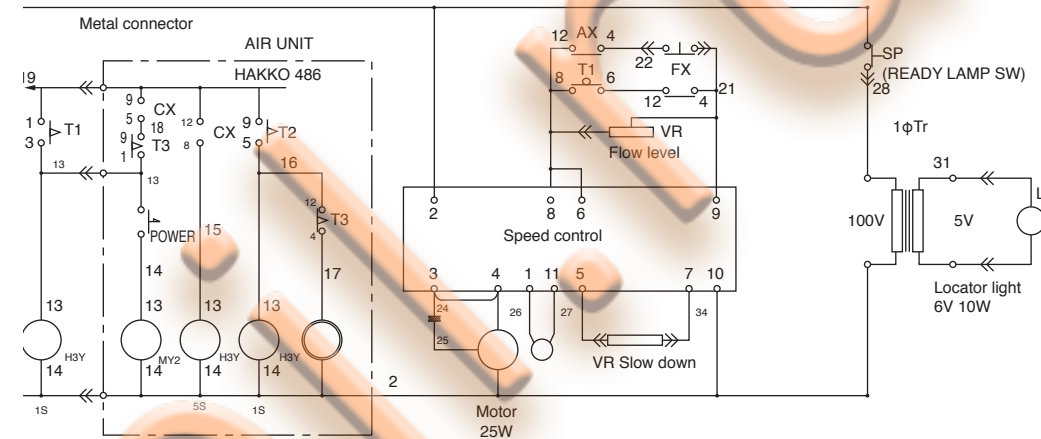

4	5	6
Plug the HAKKO 486(Air unit) into 3p metal connector of the HAKKO 485.	Plug the air hose into the side (Fig.2) of the HAKKO 486(Air unit).	Adjust the feet on the HAKKO 485 so that it is stable and level.

4. OPERATION

⚠ CAUTION

For safety reasons, be sure to ground the unit by connecting the ground wire to a grounded terminal.

First, plug the power cord into a grounded wall socket, then open the rear panel of the unit and turn on the Circuit Breaker.

Check the breaker switch by depressing the test button, approximately once a month.

Turn on the power switch on the front panel, and set key switch to MANUAL or AUTO. The unit will begin heating.

Adjust temperature (0-300°C, 32-570°F) with the temperature control meter. When operating in AUTO, adjust the Digital solder flow duration meter (standard setting: 250°C • 482°F 4sec.)

When temperature reaches the pre-set one, the temperature control lamp turns from ▼ to ■.

Shortly after, the "READY" lamp will turn on. The unit is now ready to use.

Select the appropriate flow nozzle for your IC and fix it to the solder flow outlet. Turn the locator light on and set it to the center of the IC.

NOTE : As a safety feature, the locator light will not operate until the temperature reaches the pre-set one, regardless if the switch is turned on.

Mode - AUTO

Before selecting AUTO mode, turn the key switch to MANUAL. Depress the foot switch and adjust the solder flow as desired using the solder flow dial. Then turn the key switch to AUTO mode.

Set the solder flow duration according to your needs. Put a P.W.B. on the table, then set the locator light to the center of the IC.

Depress the foot switch. Watch carefully to see when the solder has become molten. At that time remove the IC.

Should it not remove easily, depress the foot switch once more. The solder will flow only for the duration set on the flow timer.

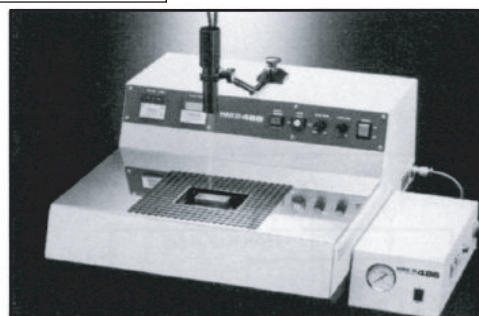

①

NOTE :
Without setting the key switch to MANUAL or AUTO, the heater will not begin heating.



③

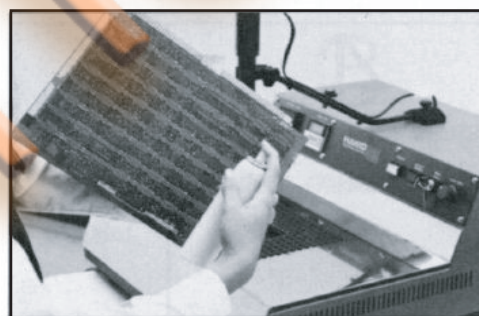

⑤

Mode - MANUAL

Turn the key switch to MANUAL mode.

Depress the foot switch and adjust the solder flow as desired using the solder flow dial.

Put a P.W.B. on the table, and set locator light to the center of IC.

Depress the foot switch. Watch carefully to see when the solder has become molten. At that time remove the IC.

NOTE : As solder continues to flow while the foot switch is depressed, remove your foot from switch just before removing IC from the table.

An inter-locking device prevents the motor, the foot switch, and the locator lamp from operating until the "READY" lamp is lit.

Compressed air cleaning - after removal of IC

Connect the HAKKO 486(AIR UNIT) to the unit with 3P metal connector. Turn the AIR UNIT switch to ON in order to prepare for cleaning. Next, switch the MODE key on the unit to AUTO, then, using a P.W.B. to test, set the solder flow duration according to your needs.

Adjust Slow down control dial, Air pressure dial, Air blow duration dial and Air blow timing dial.

Put a P.W.B. on the table and set the locator light where the IC had been. Then place the hood of the air cleaning hose over the section to be cleaned and lightly depress the foot switch. Be especially careful not to press the P.W.B. too much with your hands, as the solder will overflow through the holes. After the solder has run out, compressed air from the air hood cleans IC holes for the pre-set time period.

Other Uses

If an IC is defective or does not operate properly, it may be replaced with a new IC. Remove defective IC, spray flux on backside of board, and attach new IC using the same procedure as above.

Excessive solder on the leads of the IC or other components can be removed easily. Depress the foot switch and briefly dip the leads into the solder bath.

It is also possible to attach various sized connects by special ordering separate nozzle attachments from us.

NOTE :
After finishing the work, turn off the power switch.



②



④